



## **E07-400T10S**

**CC1101 410-450MHz 10dBm SoC SMT Wireless Module**



## Contents

Disclaimer .....	2
1.1 Brief Introduction .....	3
1.2 Features .....	3
1.3 Application .....	3
2 Specification and Parameter .....	5
2.1 RF Parameter .....	5
2.2 Hardware parameter .....	5
2.3 Electrical parameter .....	5
3 Size and pin definition .....	6
4 Basic operation .....	7
4.1 Hardware design .....	7
4.1 Software design .....	9
5 Circuit principle .....	11
6 FAQ .....	11
6.1 Communication range is too short .....	11
Due to antenna quality or poor matching between antenna and module. ....	12
6.2 Module is easy to damage .....	12
6.3 BER(Bit Error Rate) is high .....	12
7 Welding operation instruction .....	12
8 E07 series .....	12
9 Antenna recommendation .....	13
9.1 Recommendation .....	13
Revision History .....	14
About us .....	14

## **Disclaimer**

EBYTE reserves all rights to this document and the information contained herein. Products, names, logos and designs described herein may in whole or in part be subject to intellectual property rights. Reproduction, use, modification or disclosure to third parties of this document or any part thereof without the express permission of EBYTE is strictly prohibited.

The information contained herein is provided “as is” and EBYTE assumes no liability for the use of the information. No warranty, either express or implied, is given, including but not limited, with respect to the accuracy, correctness, reliability and fitness for a particular purpose of the information. This document may be revised by EBYTE at any time. For most recent documents, visit [www.ebyte.com](http://www.ebyte.com).

### Notice:

The contents of this manual may be changed due to product version upgrade or other reasons. Yibaite Electronic Technology Co., Ltd. reserves the right to modify the contents of this manual without any notice or prompt. This manual is only used as a guide. Chengdu yibaite Electronic Technology Co., Ltd. will try its best to provide accurate information in this manual. However, Chengdu yibaite Electronic Technology Co., Ltd. does not guarantee that the contents of this manual are completely correct, and all statements, information and suggestions in this manual do not constitute any express or implied warranty.

# 1 Overview

## 1.1 Brief Introduction

E07-400T10s is a 410-450MHz SMT wireless module independently developed based on MSP430FR2433 and CC1101 produced by Texas Instruments (TI), which supports secondary development.

Since the very mature MSP430FR2433 and CC1101 are adopted as the core of the module, its stability is well received by users, and there is no need to worry about compatibility. This module is mainly aimed at intelligent home, industry, scientific research and medical treatment and short-range wireless communication equipment. It can provide extensive hardware support for packet processing, data buffering, burst transmission, received signal strength indication (RSSI), idle channel evaluation (CCA), link quality indication, and wireless wake-up (WOR). Industrial grade high-precision 26MHz crystal oscillator is used to ensure reliable and stable wireless communication quality.

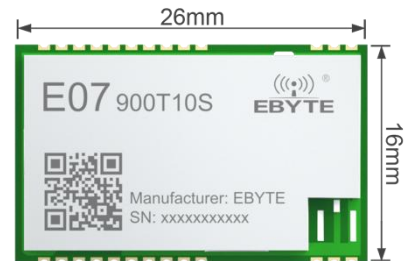

## 1.2 Features

- Under ideal conditions, the communication distance can reach 1500m;
- The maximum transmission power is 10mW, and the software is multi-level adjustable;
- Support license free ISM 433MHz band;
- Support data transmission rate of 0.6kbps ~ 500kbps;
- Support multiple modulation modes (OOK, ASK, GFSK, 2-FSK, 4-FSK and MSK);
- Independent 64 byte RX FIFO and TX FIFO;
- Support 2.5-5.5v power supply, and power supply greater than 5V can ensure the best performance;
- Industrial standard design, supporting long-term use at - 40 ~ 85 °C;
- IPEX interface, which can easily connect external antenna;
- Support RSSI (received signal strength indication) and LQI (link quality indication);
- Connect with MCU through 4-wire SPI interface, and provide 2 universal digital output pins with settable functions.

## 1.3 Application

- Smart home and industrial sensors;
- Wireless alarm safety system;
- Building automation solutions;
- Wireless industrial remote controller;
- Healthcare products;

- Advanced meter reading architecture (AMI);
- Application in automobile industry.

## 2 Specification and Parameter

### 2.1 RF Parameter

RF Parameter	Parameter Value	Remark
Operating frequency	410~450 MHz	Support ISM
Transmit power	10 dBm	The software is adjustable and needs to be developed and set by the user
Receiving sensitivity	-106 dBm	GFSK, Air data rate is 1.2kbps
FIFO	64Byte	Maximum length of single transmission
Modulation mode	GFSK(recommendation)	Support OOK、ASK、GFSK、2-FSK、4-FSK and MSK
Measured distance	1500 米	Sunny and open environment, maximum power, antenna gain 5dBi, height 2.5m, air speed 1.2kbps

### 2.2 Hardware parameter

Hardware parameters	Parameter value	Remark
RF IC	CC1101	Texas Instruments
MCU	MSP430FR2433	Texas Instruments
Core	16 bit RISC architecture	Ultra low power consumption
FLASH	15.5 KB	—
RAM	4 KB	—
Crystal oscillation frequency	26MHz	External crystal oscillator
Size	16 * 26 mm	—
Antenna	IPEX/Stamp hole	Equivalent impedance is about 50Ω
Communication interface	UART、SPI、ADC、GPIO	It needs to be developed and set by the user
Package	SMT stamp hole	Half hole, hole spacing 1.27mm
Net weight	1.2g	—

### 2.3 Electrical parameter

Electrical parameter	Min	Type	Max	Unit	Condition
----------------------	-----	------	-----	------	-----------

Voltage supply	2.5	5.0	5.5	V	≥ 5.0V ensure output power Burn the module permanently over 5.5V
Communication level	-	3.3	-	V	When using 5.0V TTL, it is recommended to add electrical level conversion
Emission current	-	35	-	mA	Instantaneous power consumption
Receiving current	-	18	-	mA	—
Sleep current	-	0.6	-	μA	Software shutdown
working temperature	-40	20	85	°C	—
Working humidity	10	60	90	%	—
Storage temperature:	-40	20	125	°C	—

### 3 Size and pin definition

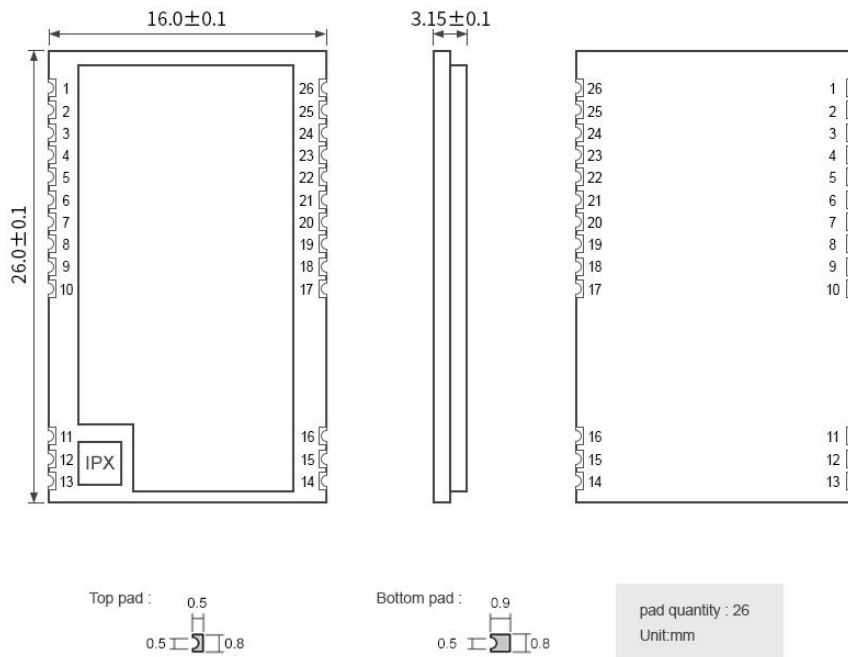

Pin No.	Item	Direction	Description
1	SWDIO	Input	For program download / debugging port, please refer to the chip manual (MSP430FR2433)
2, 11, 13 ~17, 26	GND	(-)	Ground, connected to power reference ground
3	SWCLK	Input	For program download / debugging port, please refer to the chip manual (MSP430FR2433)
4	3.3V	Input	Program download power supply 3.3V
5	P2.0/XOUT	Input/Output	Please refer to the chip manual for details (MSP430FR2433)
6	P2.1/XIN	Input/Output	Please refer to the chip manual for details (MSP430FR2433)
7	P1.4/UCA0TXD	Input/Output	Please refer to the chip manual for details (MSP430FR2433)

8	P1.5/UCA0RXD	Input/Output	Please refer to the chip manual for details (MSP430FR2433)
9	P1.6/UCA0CLK	Input/Output	Please refer to the chip manual for details (MSP430FR2433)
10	P1.7/UCA0STE	Input/Output	Please refer to the chip manual for details (MSP430FR2433)
12	ANT	Output	Antenna interface, stamp hole (50Ω special impedance)
18	P2.3	Input/Output	Please refer to the chip manual for details (MSP430FR2433)
19	P3.1/UCA1STE	Input/Output	Please refer to the chip manual for details (MSP430FR2433)
20	P2.4/UCA1CLK	Input/Output	Please refer to the chip manual for details (MSP430FR2433)
21	P2.7	Input/Output	Please refer to the chip manual for details (MSP430FR2433)
22	P2.5/UCA0RXD	Input/Output	Please refer to the chip manual for details (MSP430FR2433)
23	P2.6/UCA0TXD	Input/Output	Please refer to the chip manual for details (MSP430FR2433)
24	P3.2	Input/Output	Please refer to the chip manual for details (MSP430FR2433)
25	+5V	Input	Module power input, available for (2.5v-5.5v) input
Note <sup>1</sup> : Interior of the module, GDO0 and GDO2 of RF chip CC1101 have been connected to P3.0 and P2.2 of MCU chip MSP430FR2433 respectively. Please refer to Chapter 5 for details.			

## 4 Basic operation



### 4.1 Hardware design

- It is recommended to use a DC stabilized power supply. The power supply ripple factor is as small as possible and the module needs to be reliably grounded;
- Please pay attention to the correct connection of the positive and negative poles of the power supply, reverse connection may cause permanent damage to the module;
- Please check the power supply to ensure that between the recommended supply voltage, if exceeding the maximum, the module will be permanently damaged;
- Please check the stability of the power supply. Voltage can not fluctuate greatly and frequently;
- When designing the power supply circuit for the module, it is often recommended to reserve more than 30% of the margin, so the whole machine is beneficial for long-term stable operation;
- The module should be as far away as possible from the power supply, transformers, high-frequency wiring and other parts with large electromagnetic interference;
- Bottom Layer High-frequency digital routing, high-frequency analog routing, and power routing must be avoided under the module. If it is necessary to pass through the module, assume that the module is soldered to the Top Layer, and the copper is spread on the Top Layer of the module contact part(well grounded), it must be close to the digital part of the module and routed in the Bottom Layer;
- Assuming the module is soldered or placed over the Top Layer, it is wrong to randomly route over the Bottom Layer or other layers, which will affect the module's spurs and receiving sensitivity to varying degrees;
- It is assumed that there are devices with large electromagnetic interference around the module that will greatly affect the performance. It is recommended to keep them away from the module according to the strength of the interference. If necessary, appropriate isolation and shielding can be done;
- Assume that there are traces with large electromagnetic interference (high-frequency digital, high-frequency analog, power traces) around the module that will greatly affect the performance of the module. It is recommended to stay away from the module according to the strength of the interference. If necessary, appropriate isolation and shielding

can be done;

- If the communication line uses a 5V level, a 1k-5.1k resistor must be connected in series (not recommended, there is still a risk of damage);
- The mounting structure of antenna has a great influence on the performance of the module. It is necessary to ensure that the antenna is exposed, preferably vertically upward. When the module is mounted inside the case, use a good antenna extension cable to extend the antenna to the outside;
- The antenna must not be installed inside the metal case, which will cause the transmission distance to be greatly weakened.

### 4.1 Software design

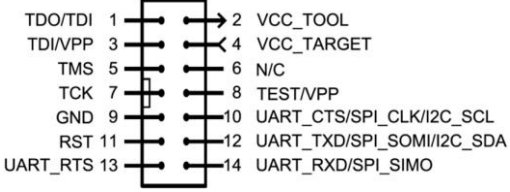
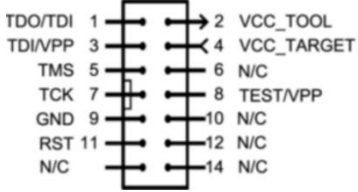
	Matters	Illustration
1	Reading materials	Before starting software development, please read relevant materials in detail: <ol style="list-style-type: none"> <li>① <a href="#">CC1101 Data manual</a>;</li> <li>② <a href="#">MSP430FR2433 Data manual</a>;</li> <li>③ <a href="#">MSP Debuggers User's Guide</a>;</li> <li>④ <a href="#">Chapter III</a> and <a href="#">Chapter V</a> of this manual;</li> </ol>
2	Simulator	Please use TI's official MSP-FET simulation tool or MSP-FET 430UIF simulation tool. <div style="display: flex; justify-content: space-around; align-items: center;"> <div style="text-align: center;">  <p><i>MSP-FET Top View</i></p> </div> <div style="text-align: center;">  <p><i>MSP-FET Bottom View</i></p> </div> </div> <div style="text-align: center; margin-top: 10px;">  <p><i>MSP-FET430UIF Top and Bottom Views</i></p> </div>
3	Commissioning wiring	The TDO / TDI pin of the simulator is connected to the SWDIO pin of the module; The TCK pin of the simulator is connected to the SWCLK pin of the module; When the module itself is powered, VCC_TARGET is connected to the 3.3V pin of the module; When powered by the simulator, VCC_TOOL is connected to the 3.3V pin of the module; The GND pin of the simulator is connected to the GND pin of the module. <div style="display: flex; justify-content: space-around; align-items: center; margin-top: 10px;"> <div style="text-align: center;">  <p><i>MSP-FET 14-Pin JTAG Connector</i></p> </div> <div style="text-align: center;">  <p><i>MSP-FET430UIF 14-Pin JTAG Connector</i></p> </div> </div>
4	Download sample code	You can download the sample project from the official website of Ebyte, and open the content as shown in the following figure



5 Project The example engineering platform is Ti CCS 10.4.0. The platform download link is:<https://www.ti.com.cn/tool/zh-cn/CCSTUDIO?keyMatch=&tisearch=search-everything&usccase=partmatches>. After opening the platform and creating the workspace, click Import CCS Projects under the project option to import the sample project, as shown in the following figure.

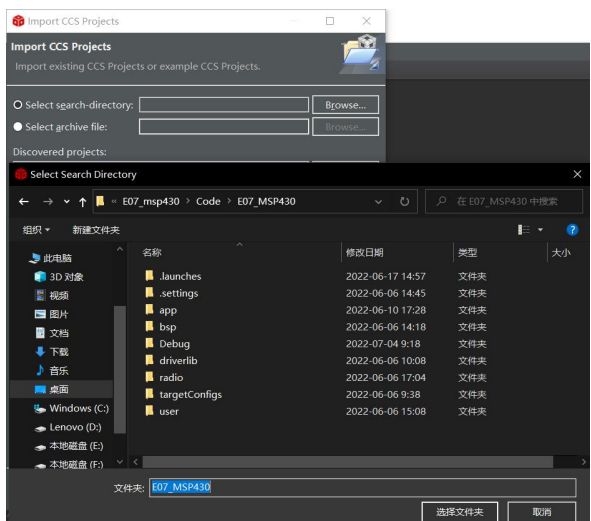

6 Download / Debug Click Load / Debug under the Run option of CCS to download / debug.

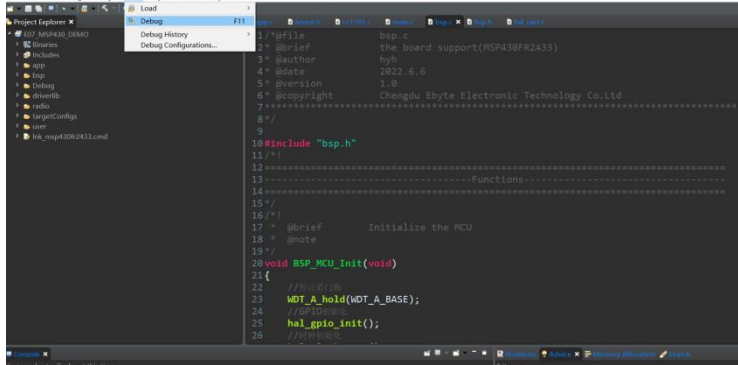

## 5 Circuit principle

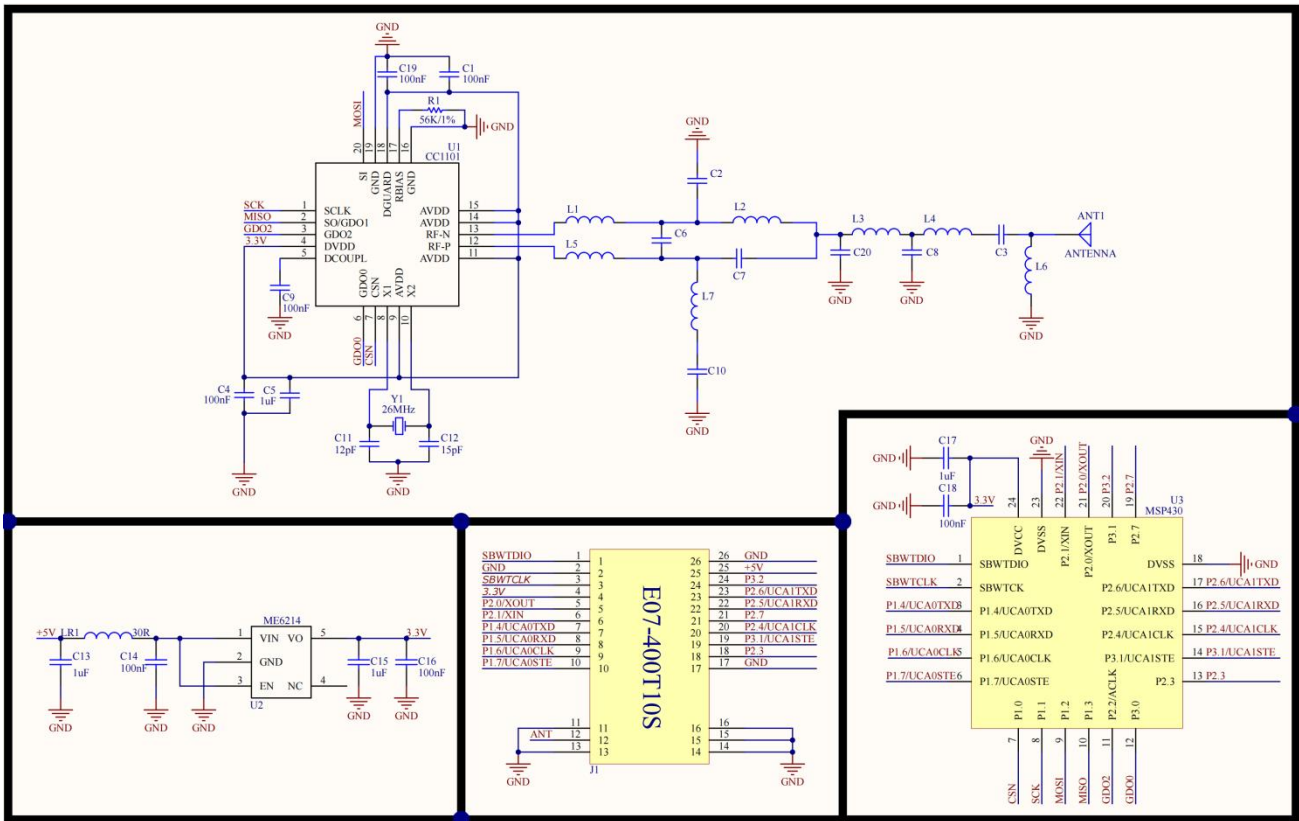

## 6 FAQ

### 6.1 Communication range is too short

- The communication distance will be affected when obstacle exists;
- Data lose rate will be affected by temperature, humidity and co-channel interference;
- The ground will absorb and reflect wireless radio wave, so the performance will be poor when testing near ground;
- Sea water has great ability in absorbing wireless radio wave, so performance will be poor when testing near the sea;
- The signal will be affected when the antenna is near metal object or put in a metal case;
- Power register was set incorrectly, air data rate is set as too high (the higher the air data rate, the shorter the distance);
- The power supply low voltage under room temperature is lower than 2.5V, the lower the voltage, the lower the transmitting power;

Due to antenna quality or poor matching between antenna and module.

## 6.2 Module is easy to damage

- Please check the power supply source, ensure it is 2.0V~3.6V, voltage higher than 3.6V will damage the module;
- Please check the stability of power source, the voltage cannot fluctuate too much;
- Please make sure antistatic measure are taken when installing and using, high frequency devices have electrostatic susceptibility;
- Please ensure the humidity is within limited range, some parts are sensitive to humidity;
- Please avoid using modules under too high or too low temperature.

## 6.3 BER(Bit Error Rate) is high

- There are co-channel signal interference nearby, please be away from interference sources or modify frequency and channel to avoid interference;
- The clock waveform on the SPI is not standard, check whether there is interference on the SPI line, and the SPI bus routing should not be too long;
- Poor power supply may cause messy code. Make sure that the power supply is reliable;
- The extension line and feeder quality are poor or too long, so the bit error rate is high.

## 7 Welding operation instruction

This product is a SMT module. When welding the module, the welding personnel must follow the electrostatic discharge operation specification.

This product is an electrostatic sensitive product. The module may be permanently damaged if it is not welded according to the rules.

## 8 E07 series

Model No.	IC	Frequency	Tx power	Distance	Package	Antenna
		Hz	dBm	m		
<a href="#">E07-400M10S</a>	CC1101	433M	10	1500	SMD	Stamp hole
<a href="#">E07-900M10S</a>	CC1101	868M/915M	10	1500	SMD	Stamp hole
All models of E07 series wireless modules can be interconnected						

## 9 Antenna recommendation

### 9.1 Recommendation

The antenna is an important role in the communication process. A good antenna can largely improve the communication system. Therefore, we recommend some antennas for wireless modules with excellent performance and reasonable price.

Model No.	Type	Frequency	Gain dBi	Size	Cable	Interfac	Feature
		Hz	dBi	mm	cm		
<a href="#">TX433-NP-4310</a>	Flexible antenna	433M	2.0	10x43	-	Welding	FPC soft antenna
<a href="#">TX433-JZ-5</a>	Rubber antenna	433M	2.0	30	-	SMA-J	Short straight & omnidirectional
<a href="#">TX433-JZG-6</a>	Rubber antenna	433M	2.5	50	-	SMA-J	Short straight & omnidirectional
<a href="#">TX433-JW-5</a>	Rubber antenna	433M	2.0	50	-	SMA-J	Fixed bending & omnidirectional
<a href="#">TX433-JWG-7</a>	Rubber antenna	433M	2.5	110	-	SMA-J	Fixed bending & omnidirectional
<a href="#">TX433-JK-11</a>	Rubber antenna	433M	2.5	110	-	SMA-J	Bendable rubber & omnidirectional
<a href="#">TX433-JK-20</a>	Rubber antenna	433M	3.0	200	-	SMA-J	Bendable rubber & omnidirectional
<a href="#">TX433-XPL-100</a>	Sucker antenna	433M	3.5	185	100	SMA-J	Small sucker & high cost performance
<a href="#">TX433-XP-200</a>	Sucker antenna	433M	4.0	190	200	SMA-J	Small sucker & low loss
<a href="#">TX433-XP-300</a>	Sucker antenna	433M	6.0	965	300	SMA-J	Small sucker & high gain
<a href="#">TX433-XP-300</a>	吸盘天线	433M	6.0	965	300	SMA-J	小型吸盘天线，高增益

## Revision History

Version	Date	Description	Maintainer
1.0	2022-07-14	Initial version	Yan
1.1	2022-07-21	Content added	Yan

## About us

Technical support: [support@cdebyte.com](mailto:support@cdebyte.com)

Documents and RF Setting download link: <https://www.cdebyte.com>

Thank you for using Ebyte products! Please contact us with any questions or suggestions: [info@cdebyte.com](mailto:info@cdebyte.com)

-----  
Phone: +86 028-61399028

Web: <https://www.cdebyte.com>

Address: B5 Mould Park, 199# Xiqu Ave, High-tech District, Sichuan, China

 **EBYTE** Chengdu Ebyte Electronic Technology Co.,Ltd.