



E72-2G4M20S1C User Manual

CC2674P10 Multi-Function SoC Wireless Module



Contents

Disclaimer	1
1 Product Overview	1
1.1 Introduction	1
1.2 Features	1
1.3 Application	1
2.Specification and parameter	1
2.1 Limit parameter	1
2.2 Operating parameter	1
3 Size and pin definition	2
4 Development	4
5 Basic operation	4
5.1 Hardware Design	4
5.2 Software edit	6
5.3 Environmental construction	6
6 FAQ	16
6.1 Communication range is too short	16
6.2 Module is easy to damage	16
6.3 BER(Bit Error Rate) is high	16
7 Production guidance	17
7.1 Reflow soldering temperature	17
7.2 Reflow soldering curve	18
8 Package for batch order	19
Revision history	19

Disclaimer

EBYTE reserves all rights to this document and the information contained herein. Products, names, logos and designs described herein may in whole or in part be subject to intellectual property rights. Reproduction, use, modification or disclosure to third parties of this document or any part thereof without the express permission of EBYTE is strictly prohibited.

The information contained herein is provided “as is” and EBYTE assumes no liability for the use of the information. No warranty, either express or implied, is given, including but not limited, with respect to the accuracy, correctness, reliability and fitness for a particular purpose of the information. This document may be revised by EBYTE at any time. For most recent documents, visit www.cdebyte.com.

1 Product Overview

1.1 Introduction

E72-2G4M20S1C is a multi-protocol 2.4GHz wireless chip on chip system module independently developed based on CC2674P10 produced by TI, with a transmission power of 20dBm. It integrates an ARM microcontroller and high-performance wireless transceiver internally, and uses an industrial grade 48MHz high-precision low-temperature drift crystal oscillator.

The module leads out all IO ports of the microcontroller, and the chip comes with a powerful 48 MHz Arm[®] Cortex[®]- M33 processor, internal integrated power amplifier, powerful peripherals, and up to 26 GPIOs allow for multi-dimensional development. CC2674P has great potential to become the preferred wireless microcontroller for future smart furniture, IoT transformation, and industrial automation.

As this module is a pure hardware SoC module, it requires users to program it before use.



1.2 Features

- Built-in high-performance low-power Arm[®] Cortex[®] - M33 processor with a clock speed of up to 48MHz;
- Rich resources, 1024KB FLASH, 256KB RAM;
- Support 1.9-3.8V power supply, with power supply greater than 3.3V ensuring optimal performance;
- Transmitting power of 20dBm;
- Under ideal conditions, the communication distance can reach 620m;
- The module includes a 48M high-speed crystal oscillator/32.768k low-speed crystal oscillator;
- Industrial grade standard design, supporting long-term use at -40~+85 °C;
- 2-pin cJTAG and JTAG debugging
- Wireless protocol: Thread, Zigbee[®], Bluetooth[®] 5.3 Low Energy, IEEE 802.15.4, 6LoWPAN, proprietary systems, SimpleLink[™] TI 15.4-Stack (2.4 GHz), Dynamic Multiprotocol Manager (DMM) driver
- Receiving sensitivity: -105 dBm for 802.15.4 (2.4 GHz), -104 dBm for Bluetooth 125-kbps (LE Coded PHY)

1.3 Application

- Building automation
 - Building Security System - Motion Detectors, Electronic Intelligent Door Locks, Door and Window Sensors, Garage Door Systems, Gateways
 - HVAC - Thermostat, Wireless Environment, Sensors, HVAC System Controller, Gateway
 - Fire Safety System - Smoke and Temperature Detectors, Fire Alarm Control Panel (FACP)
 - Video surveillance - IP network camera

Elevators and escalators - elevator main, elevator and escalator control panel;

- Grid infrastructure

Smart electricity meters - water meters, gas meters, electricity meters, and heat cost allocators

Grid communication - wireless communication. Remote sensor application

Other alternative energy sources - energy collection

- Industrial transportation - asset tracking

- Factory automation and control

- Medical equipment

- Electronic Point of Sale (EPOS) - Electronic Shelves

- Label (ESL)

2. Specification and parameter

2.1 Limit parameter

Main parameter	Performance		Notes
	Min.	Max.	
Power supply (V)	0	3.8	Voltage over 3.8V will cause permanent damage to module
Blocking power (dBm)	-	10	Chances of burn is slim when modules are used in short distance
Operating temperature (°C)	-40	85	

2.2 Operating parameter

Main parameter		Performance			Remark
		Min	Typ.	Max.	
Operating voltage (V)		1.9	3.3	3.8	≥ 3.3 V ensures output power
Communication level (V)		-	3.3	-	For 5V TTL, it may be at risk of burning down
Operating temperature (°C)		-40	-	+85	Industrial design
Operating frequency (MHz)		2400	-	2480	-
Power consumption	Transmitting current [mA]	-	76.3	-	Instant power consumption@20dBm
	Receiving current [mA]	-	9.51	-	-
	Turn-off current [μ A]	-	1.4	-	-
Max Tx power (dBm)		19	19.5	20	-
Receiving sensitivity (dBm)		-	-105	-	Bluetooth 125-kbps (LE Coded PHY)

Main parameter	Description	Remark
Distance for reference	620m	Test condition: clear and open area, antenna gain: 2dBi, antenna height: 2m, air data rate: 1Mbps
Crystal frequency	48MHz/32.768k	High speed 48MHz/low speed 32.768k
Supported protocol	Bluetooth 5.3 Low Energy Zigbee Thread	-
Package	SMD	-
Interface	1.27mm	Stamp hole
IC full name	CC2674P106T0RGZ	-
FLASH	1024KB	-
RAM	256KB	-

Core	Arm ® Cortex ® -M33	-
Size	28.7*17.5mm	-
RF antenna	PCB antenna	The equivalent impedance is about 50 Ω. The factory defaults to onboard PCB antennas. If you have any IPEX antenna requirements, please consult online customer service.
Product weight	1.9±0.1g	-

3 Size and pin definition

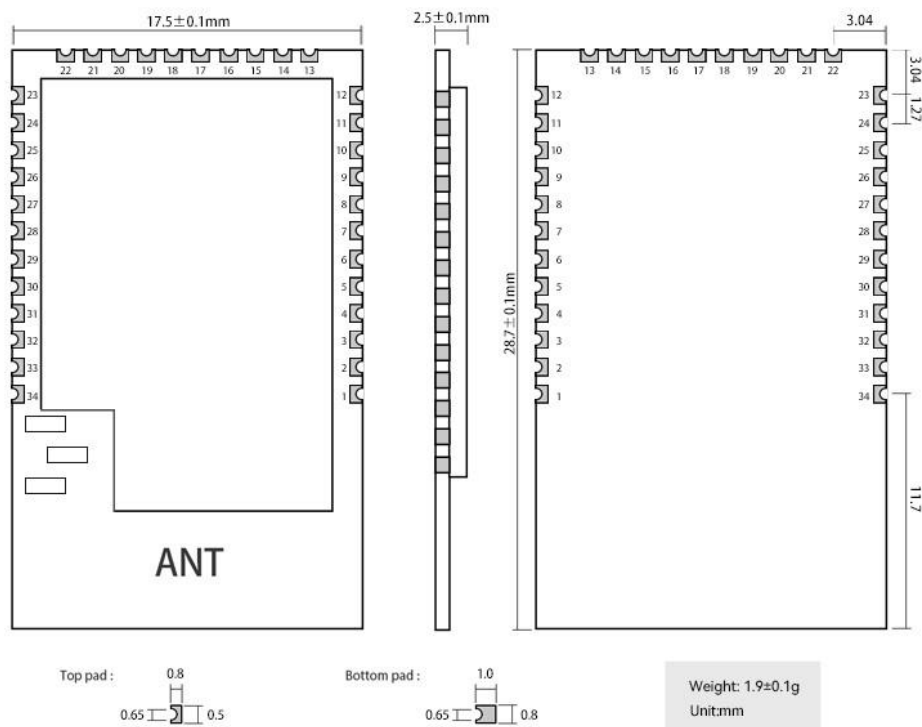

No.	Name	Direction	Function
1	GND	-	Ground, connecting to power reference ground
2	DIO_7	Input/Output	Configurable GPIO(refer to CC2674P106T0RGZ datasheet)
3	DIO_8	Input/Output	Configurable GPIO(refer to CC2674P106T0RGZ datasheet)
4	DIO_9	Input/Output	Configurable GPIO(refer to CC2674P106T0RGZ datasheet)
5	DIO_10	Input/Output	Configurable GPIO(refer to CC2674P106T0RGZ datasheet)
6	DIO_11	Input/Output	Configurable GPIO(refer to CC2674P106T0RGZ datasheet)
7	DIO_12	Input/Output	Configurable GPIO(refer to CC2674P106T0RGZ datasheet)
8	DIO_13	Input/Output	Configurable GPIO(refer to CC2674P106T0RGZ datasheet)
9	DIO_14	Input/Output	Configurable GPIO(refer to CC2674P106T0RGZ datasheet)
10	DIO_15	Input/Output	Configurable GPIO(refer to CC2674P106T0RGZ datasheet)
11	GND	-	Ground, connecting to power reference ground

12	GND	-	Ground, connecting to power reference ground
13	JTAG_TMSC	Input/Output	JTAG_TMSC
14	JTAG_TCKC	Input/Output	JTAG_TCKC
15	DIO_16	Input/Output	Configurable GPIO,JTAG_TDO(refer to CC2674P106T0RGZ datasheet)
16	DIO_17	Input/Output	Configurable GPIO,JTAG_TDI(refer to CC2674P106T0RGZ datasheet)
17	DIO_18	Input	Configurable GPIO(refer to CC2674P106T0RGZ datasheet)
18	DIO_19	Input/Output	Configurable GPIO(refer to CC2674P106T0RGZ datasheet)
19	GND	Input/Output	Ground, connecting to power reference ground
20	VCC	-	Module power supply positive reference voltage, voltage range 1.9~3.8V
21	DIO_20	Input/Output	Configurable GPIO(refer to CC2674P106T0RGZ datasheet)
22	DIO_21	Input/Output	Configurable GPIO(refer to CC2674P106T0RGZ datasheet)
23	GND	Input/Output	Ground, connecting to power reference ground
24	RESET_N	Input	Reset pin, low level active
25	DIO_22	Input/Output	Configurable GPIO(refer to CC2674P106T0RGZ datasheet)
26	DIO_23	Input/Output	Configurable GPIO(refer to CC2674P106T0RGZ datasheet)
27	DIO_24	Input/Output	Configurable GPIO(refer to CC2674P106T0RGZ datasheet)
28	DIO_25	Input/Output	Configurable GPIO(refer to CC2674P106T0RGZ datasheet)
29	DIO_26	Input/Output	Configurable GPIO(refer to CC2674P106T0RGZ datasheet)
30	DIO_27	Input/Output	Configurable GPIO(refer to CC2674P106T0RGZ datasheet)
31	DIO_28	Input/Output	Configurable GPIO(refer to CC2674P106T0RGZ datasheet)
32	DIO_29	Input/Output	Configurable GPIO(refer to CC2674P106T0RGZ datasheet)
33	DIO_30	Input/Output	Configurable GPIO(refer to CC2674P106T0RGZ datasheet)
34	GND	Input/Output	Ground, connecting to power reference ground

4 Development

No.	Keyword	Notice
1	Programming	The module is an SOC module with its own GPIO port, you can use an XDS100 dedicated downloader to download program
2	Test board	Not available

5 Basic operation

5.1 Hardware Design

- It is recommended to use a DC stabilized power supply. The power supply ripple factor is as small as possible, and the module needs to be reliably grounded.;
- Please pay attention to the correct connection of the positive and negative poles of the power supply. Reverse connection may cause permanent damage to the module;
- Please check the power supply to ensure it is within the recommended voltage otherwise when it exceeds the maximum value the module will be permanently damaged;
- Please check the stability of the power supply, the voltage can not be fluctuated frequently;
- When designing the power supply circuit for the module, it is often recommended to reserve more than 30% of the margin, so the whole machine is beneficial for long-term stable operation.;
- The module should be as far away as possible from the power supply, transformers, high-frequency wiring and other parts with large electromagnetic interference.;
- High-frequency digital routing, high-frequency analog routing, and power routing must be avoided under the module. If it is necessary to pass through the module, assume that the module is soldered to the Top Layer, and the copper is spread on the Top Layer of the module contact part(well grounded), it must be close to the digital part of the module and routed in the Bottom Layer;
- Assuming the module is soldered or placed over the Top Layer, it is wrong to randomly route over the Bottom Layer or other layers, which will affect the module's spurs and receiving sensitivity to varying degrees;
- It is assumed that there are devices with large electromagnetic interference around the module that will greatly affect the performance. It is recommended to keep them away from the module according to the strength of the interference. If necessary, appropriate isolation and shielding can be done;
- Assume that there are traces with large electromagnetic interference (high-frequency digital, high-frequency analog, power traces) around the module that will greatly affect the performance of the module. It is recommended to stay away from the module according to the strength of the interference. If necessary, appropriate isolation and shielding can be done.
- Try to stay away from some physical layers such as TTL protocol at 2.4GHz , for example: USB3.0;
- The mounting structure of antenna has a great influence on the performance of the module. It is necessary to ensure that the antenna is exposed, preferably vertically upward. When the module is mounted inside the case, use a good

antenna extension cable to extend the antenna to the outside;

- The antenna must not be installed inside the metal case, which will cause the transmission distance to be greatly weakened.

5.2 Software edit

- The core of this module is CC2674P, and users can fully operate according to the CC2674P chip manual

Attention: The chip used in the module is in DC/DC mode internally

The module comes with our own RF switch, please strictly follow the truth table for operation

- Truth Table

DIO_6	DIO_5	Transmit(TX)	Receive(RX)
Low	High	ON	OFF
High	Low	OFF	ON

- Burning program: The module is an SOC module with a built-in GPIO port, and the program is downloaded using an XDS100 dedicated downloader.
- Program Download Interface Definition:

E72 pin	XDS100 port
JTAG_TMSC	TMS
JTAG_TCKC	TCK
RESET_N	SRSTN
GND	DGND
VCC	TVD

JTAG接口定义
XDS100V3 JTAG定义

TMS	1	2	TRSTN
TDI	3	4	DIS
TVD	5	6	NC
TDO	7	8	DGND
RTCK	9	10	DGND
TCK	11	12	DGND
EMU0	13	14	EMU1
SRSTN	15	16	DGND
EMU2	17	18	EMU3
EMU4	19	20	DGND

5.3 Environmental construction

5.3.1 Installation preparation

Need to prepare SDK 7.10.01.24, CCS 12.3.0

5.3.2 Installation step

- Download the SDK from the CC2674P10 chip introduction interface on TI's official website.

Home / Wireless connectivity / Low-power 2.4-GHz products

NEW

CC2674P10 ✔ ACTIVE

Notifications

SimpleLink™ Arm® Cortex®-M33 multiprotocol 2.4-GHz wireless MCU with 1-MB flash and power amplifier

[Order now](#)

DATA SHEET [CC2674P10 SimpleLink™ High-Performance Multiprotocol 2.4-GHz Wireless MCU with Integrated Power Amplifier datasheet \(Rev. A\)](#) PDF | HTML

ERRATA

[CC2674P10 SimpleLink™ Wireless MCU Device Revision B \(Rev. B\)](#)

[Product details](#) | [Technical documentation](#) | [Design & development](#) | [Ordering & quality](#) | [Support & training](#)

Product details

This LaunchPad™ development kit speeds development on devices with an integrated power amplifier and multi-band radio support for concurrent Sub-1 GHz and 2.4-GHz operation. Protocols supported include Bluetooth® Low Energy, Wi-SUN®, Thread, Zigbee®, TI 15.4 stack and 2.4 GHz (...)

Software development



SOFTWARE DEVELOPMENT KIT (SDK)

SIMPLELINK-LOWPOWER-F2-SDK – SimpleLink™ Low Power F2 software development kit (SDK) for the CC13x1, CC13x2, CC13x4, CC26x1, CC26x2 and CC26x4 devices

[Browse](#)

[Download options](#)

The SimpleLink™ Low Power SDKs support the CC13xx, CC23xx and CC26xx family of products. Together, these SDKs provide comprehensive software packages for the development of Sub-1 GHz and 2.4 GHz applications including support for *Bluetooth®* Low Energy, Mesh, Zigbee®, Matter, Thread, (...)

[Supported products & hardware](#)

Choose 7.10.01.24 version.

Home / Wireless connectivity / Low-power 2.4-GHz products

NEW

CC2674P10 ✔ ACTIVE

Notifications

SimpleLink™ Arm® Cortex®-M33 multiprotocol 2.4-GHz wireless MCU with 1-MB flash and power amplifier

[Order now](#)

DATA SHEET [CC2674P10 SimpleLink™ High-Performance Multiprotocol 2.4-GHz Wireless MCU with Integrated Power Amplifier datasheet \(Rev. A\)](#) PDF | HTML

ERRATA

[CC2674P10 SimpleLink™ Wireless MCU Device Revision B \(Rev. B\)](#)

[Product details](#) | [Technical documentation](#) | [Design & development](#) | [Ordering & quality](#) | [Support & training](#)

Product details

1. The downloaded SDK package is directly installed in the default path.

5.3.3 CCS Operation Step

1. Import SDK project, open CCS, and select Import in the project.

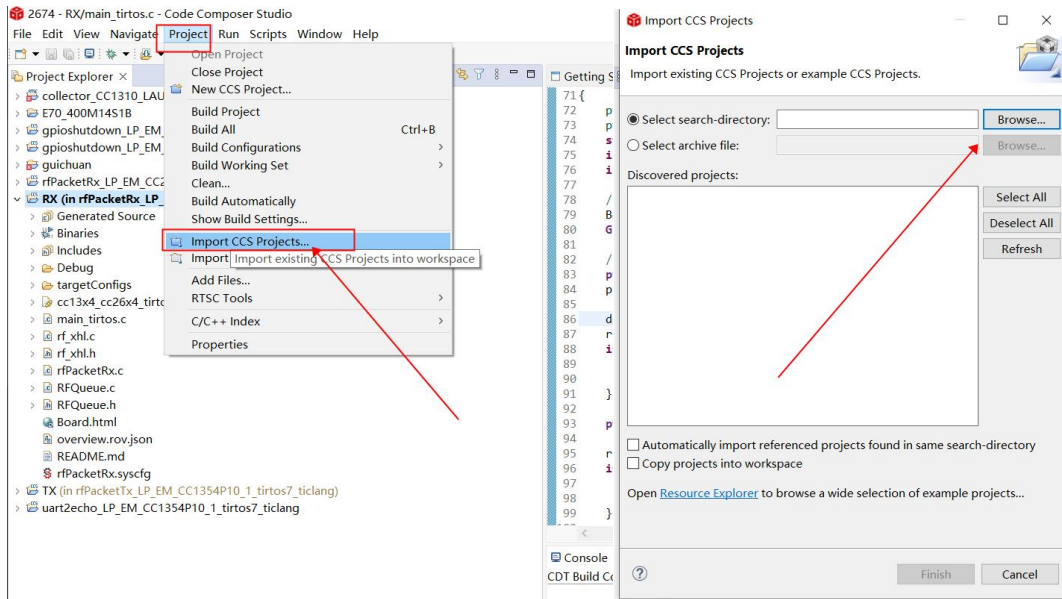

1. Taking the recipient as an example for import, select the model LP_EM_CC1354P10_1

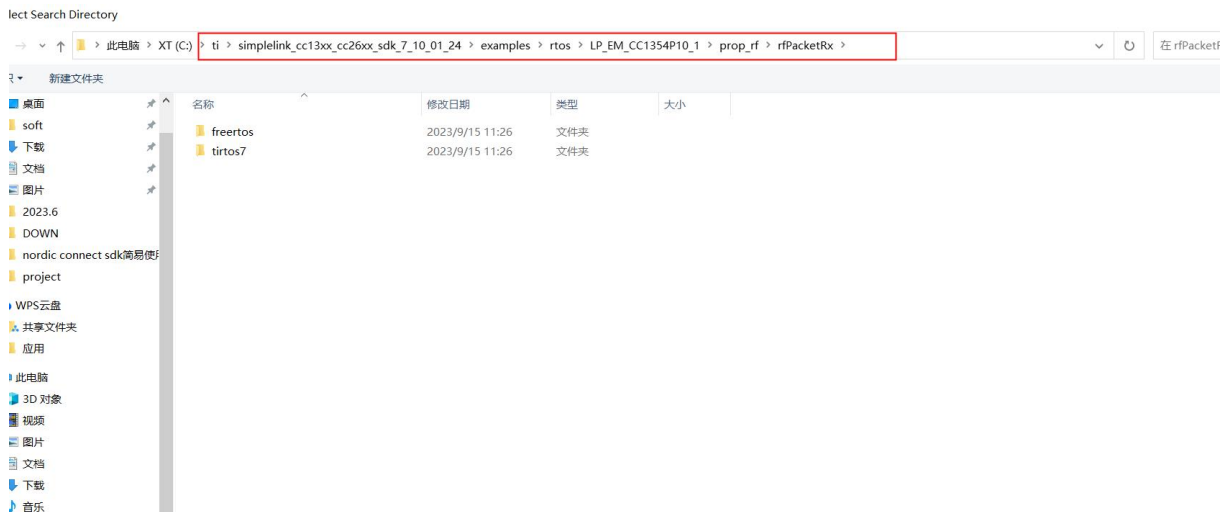

2. Choose tirtos here. If you choose freertos, you need to go to the next freertos on the internet and configure the compilation environment, which is not used in this document.

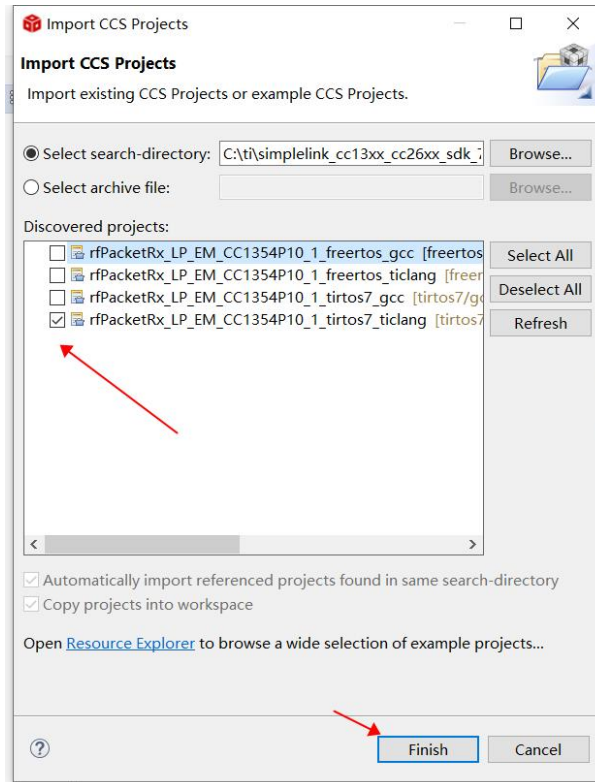

2. After importing, click on compile

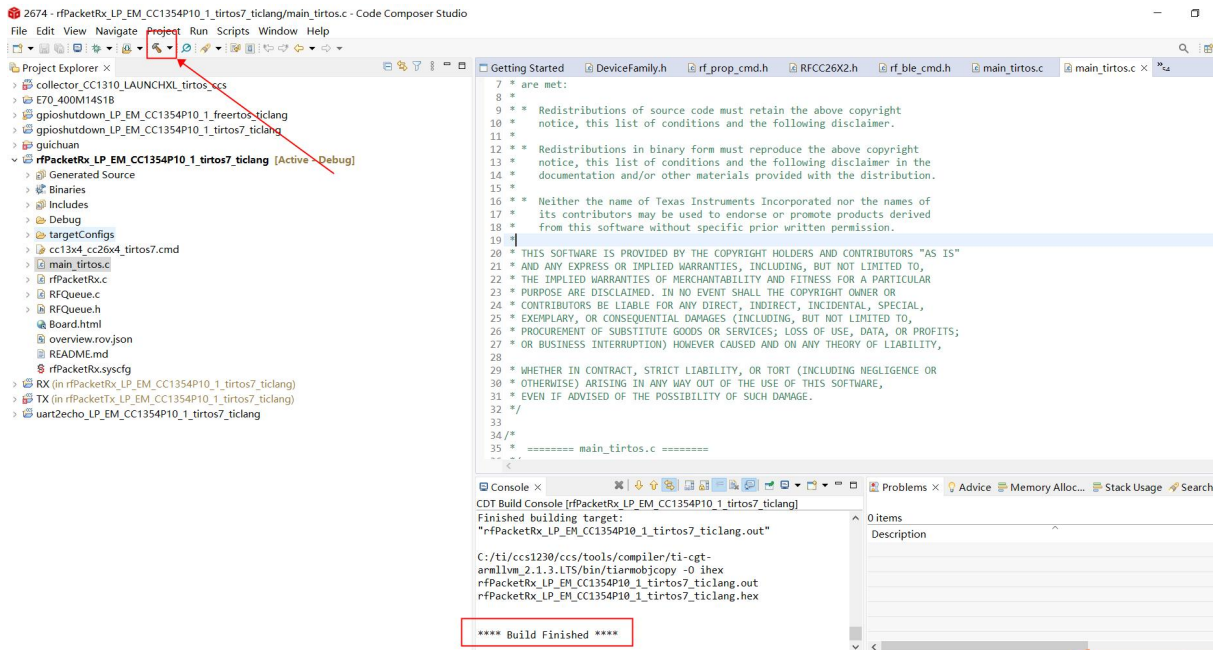

5.3.4 Code Migration

This section is for reference only. For code migration details, please refer to the TI official migration guide:

https://dev.ti.com/tirex/explore/content/simplelink_cc13xx_cc26xx_sdk_7_10_01_24/docs/thread/html/cc13xx_cc26xx/software-on-cc13x4-26x4.html

1. First, change the board introduction to the CC2674P10 chip model

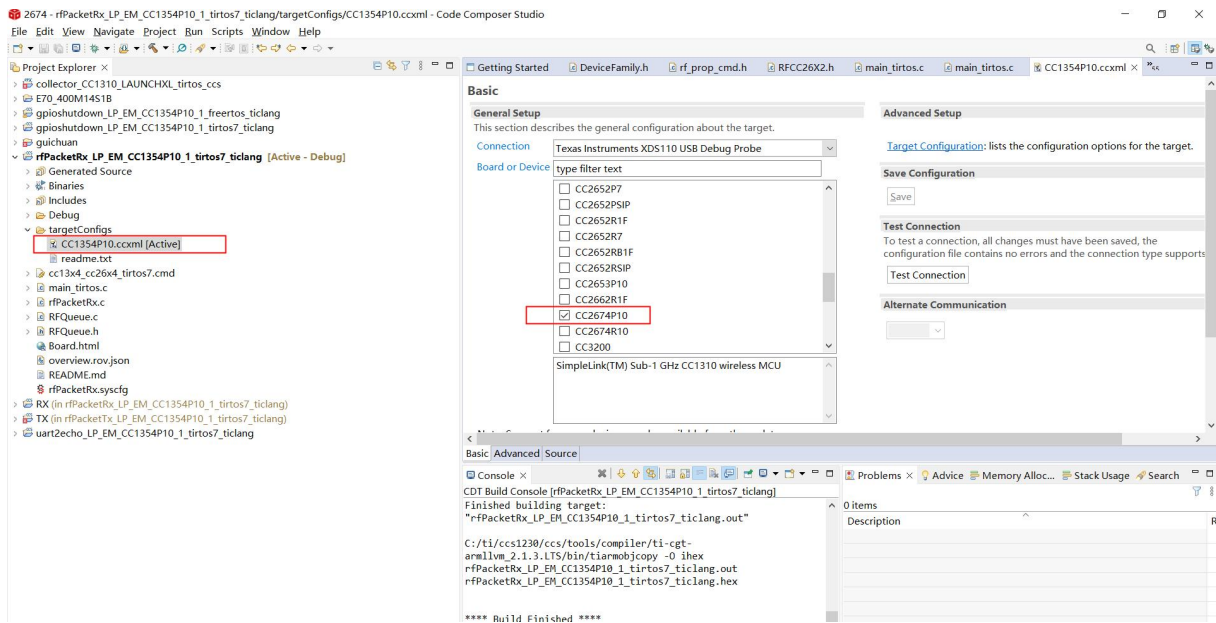

2. Continue to modify the project name

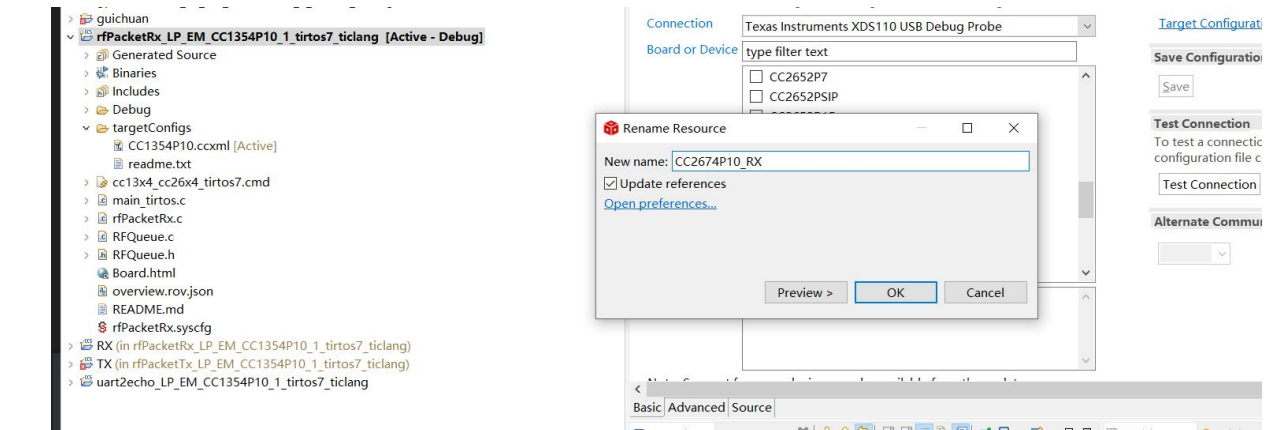
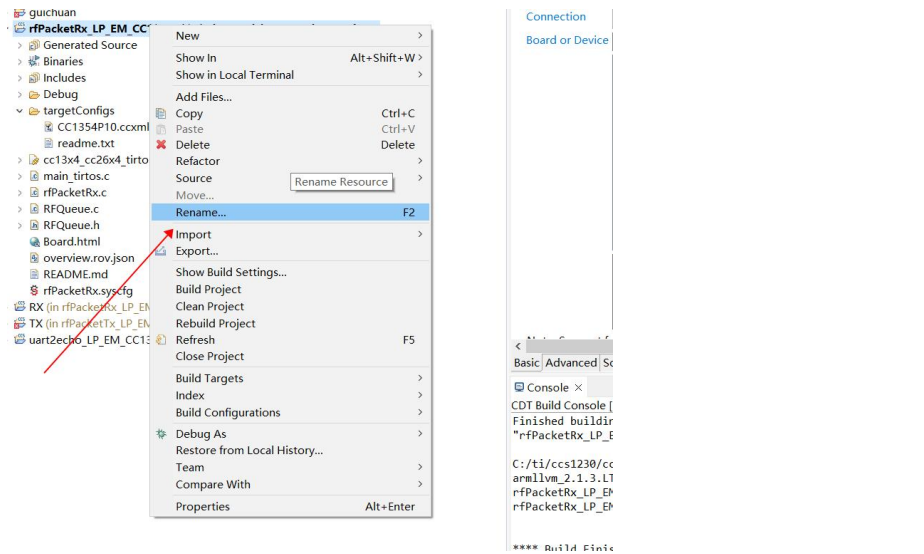

3 Modify device series

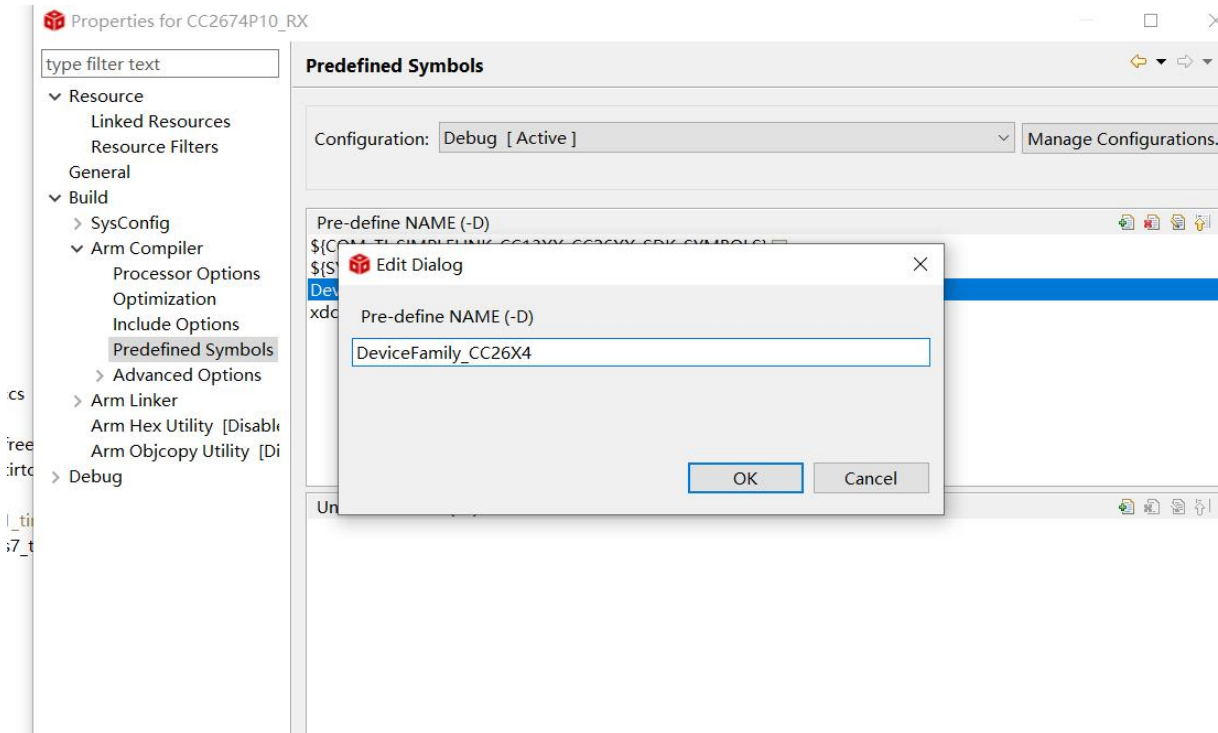
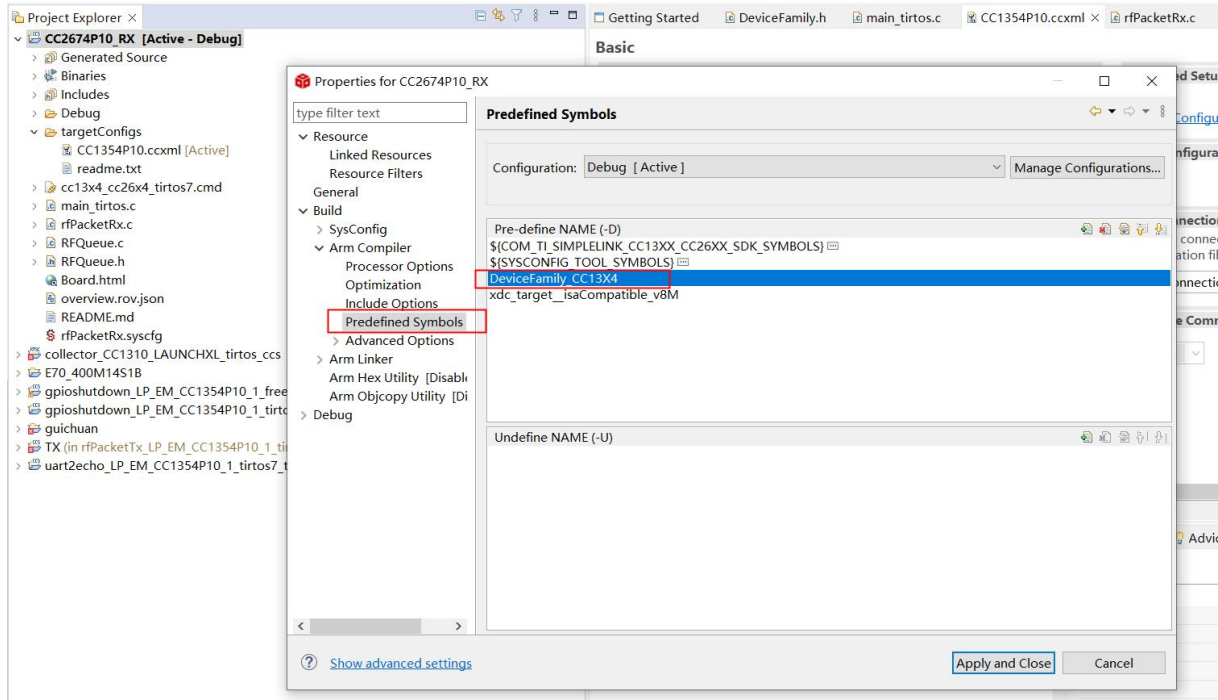

4 Modify device view

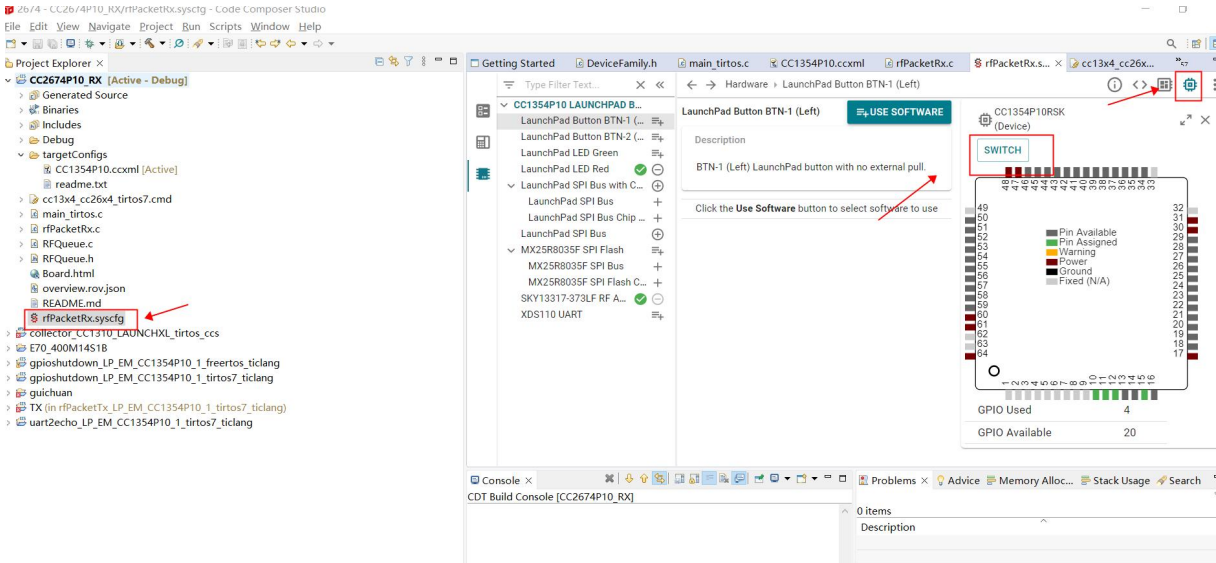

5 Modify to settings below

PropRF Migration Guidelines

- PHY settings are not common across all devices, verify they match your desired application and modify accordingly
- Migration from R to P devices requires different rf commands and high pa setup
- More Detailed Guidelines: [Link to Docs](#)

Setting	Current Value	New Value
Board	CC1354P10 LaunchPad Band 1	None
Device	CC1354P10RSK	2674P10RGZ
Part	Default	Default
Package	RSK	RGZ
Lock		<input type="checkbox"/>
PinMux		<input type="checkbox"/>

After modification, it will be found that syscfg reports an error, which is a normal phenomenon

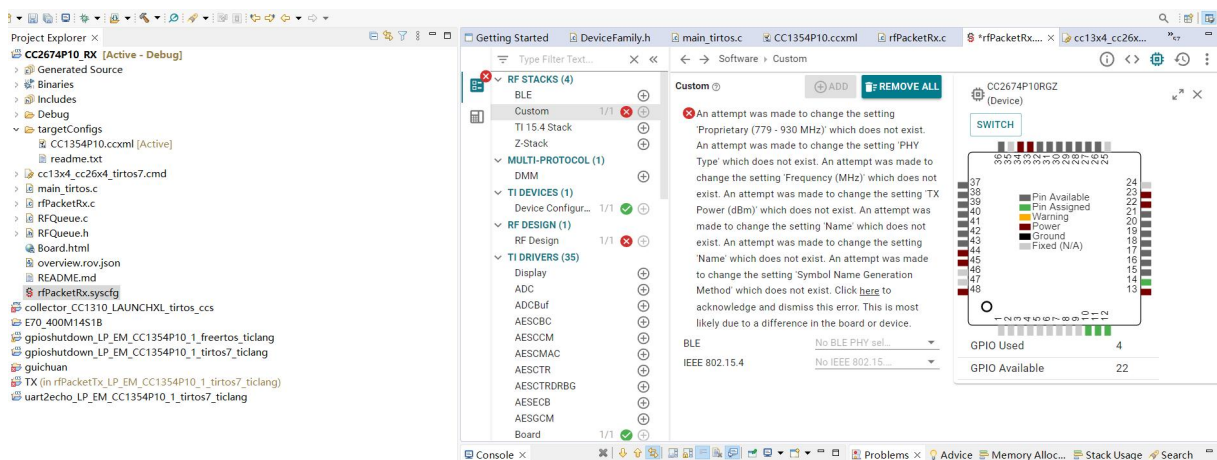

First, select Accept on the RF Design interface

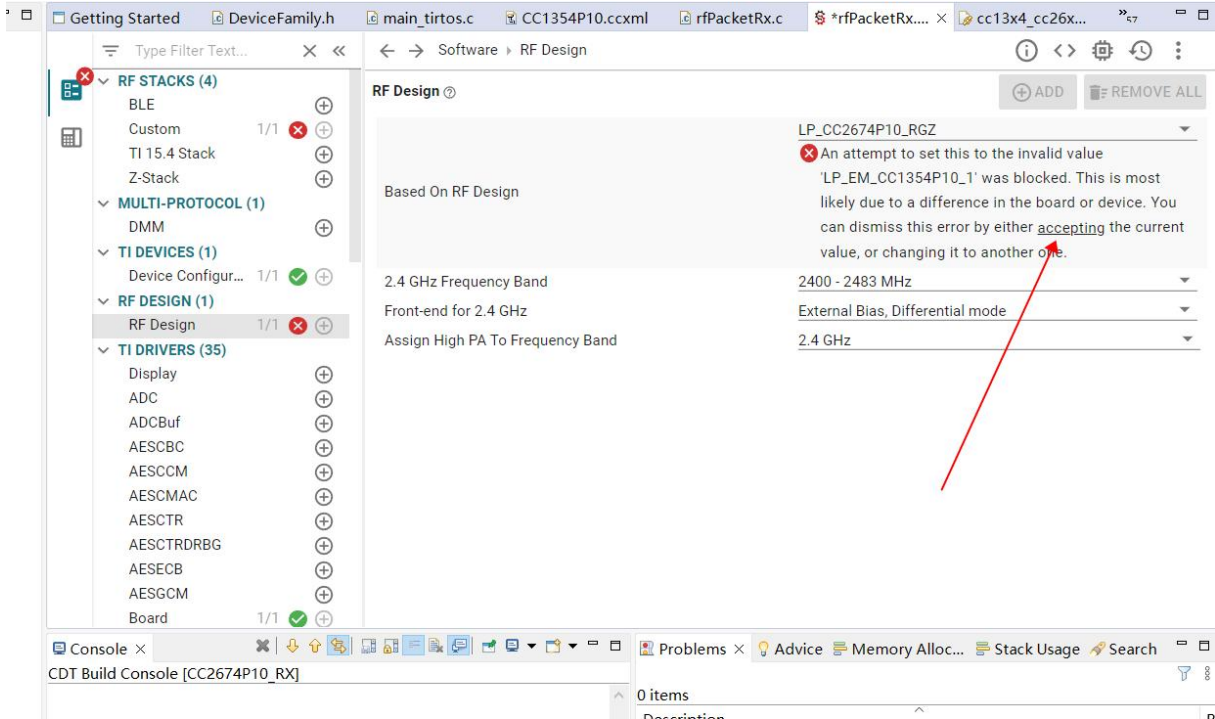

Return to Custom, check BLE, 1 Mbps, LE 1M, and then click here

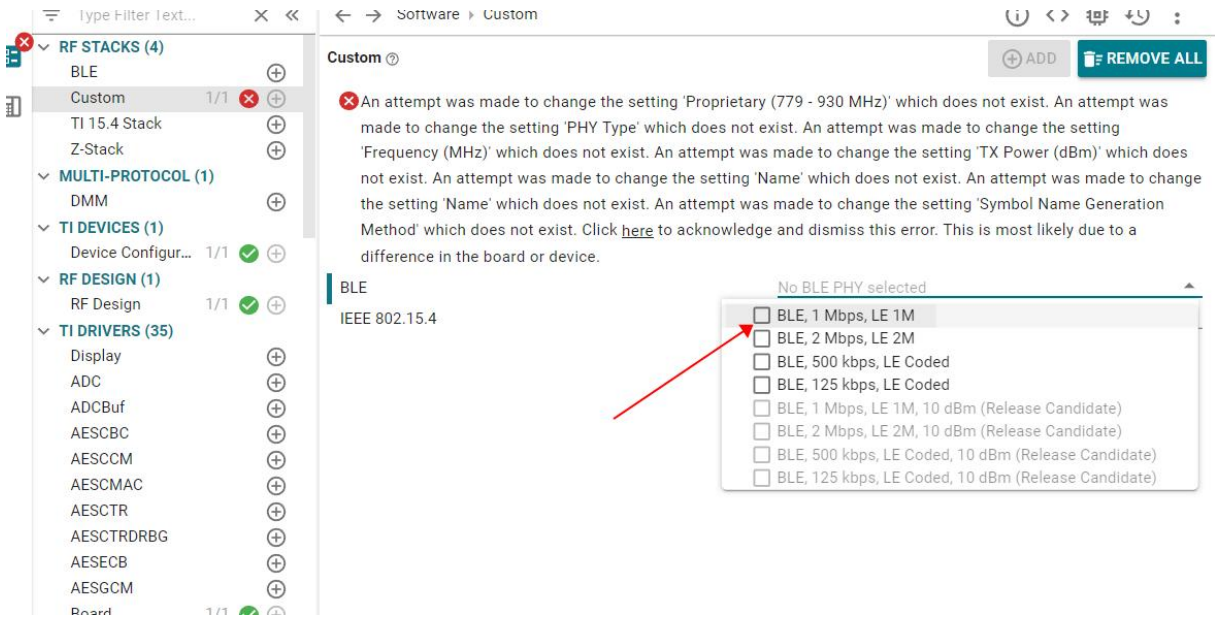

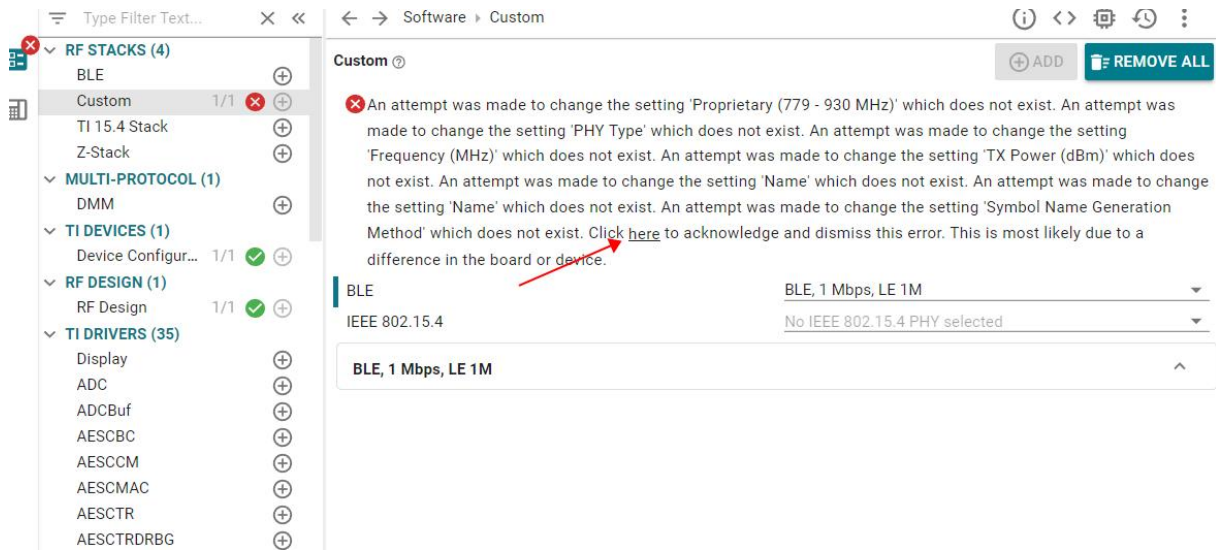

Afterwards, you can choose to check PA to increase power, but this area is only checked and needs to be used in conjunction with the pin control PA pin during normal use. So far, if compiling, errors will still be reported because there are problems with the function name and structure of the RF file. It needs to be modified again in order to use it properly. It is recommended to change the Symbol Name to Legacy in the screenshot below, or it can be left unchanged.

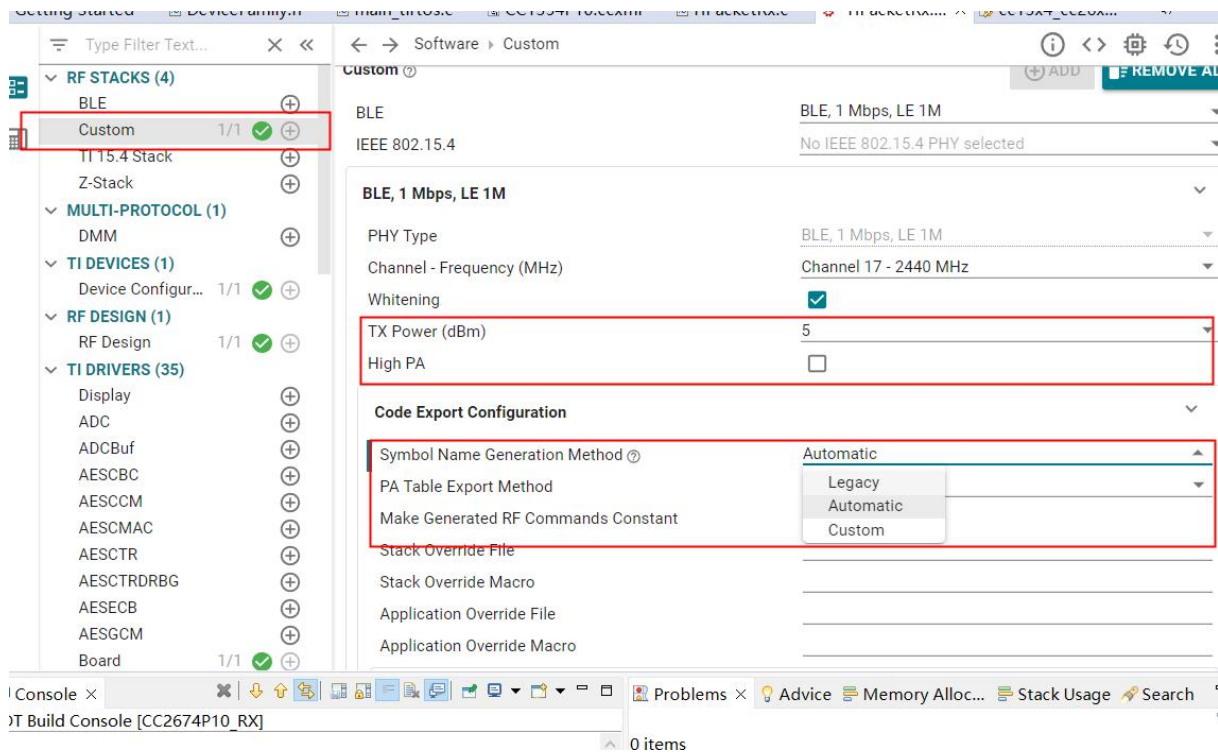

If using the rfPacket routine, it is also necessary to use the main_ Add a function to the tirtos. c file

```

46
47/* Example/Board Header files */
48#include "ti_drivers_config.h"
49
50#if defined(CONFIG_LP_CC2674R10_FPGA)
51#include <ti/drivers/power/PowerCC26XX.h>
52#include "ti/devices/DeviceFamily.h"
53#include DeviceFamily_constructPath(driverlib/ioc.h)
54#endif
55
56extern void *mainThread(void *arg0);
57
58/* Stack size in bytes */
59#define THREADSTACKSIZE 2096
60
61
62void __attribute__((weak)) rFDriverCallbackAntennaSwitching (RF_Handle client, RF_GlobalEvent events, void *arg)
63{
64
65}
66
67/*
68 * ===== main =====
    
```

5.3.5 Firmware position

1. The firmware location is in the Debug section of the project directory.

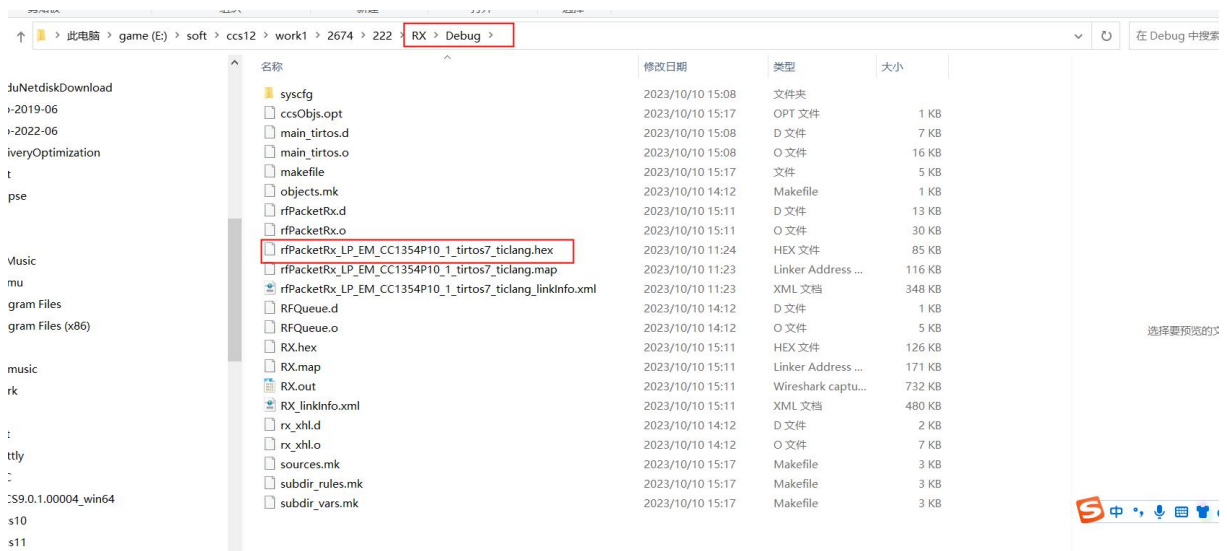

6 FAQ

6.1 Communication range is too short

- The communication distance will be affected when obstacle exists.
- Data lose rate will be affected by temperature, humidity and co-channel interference.
- The ground will absorb and reflect wireless radio wave, so the performance will be poor when testing near ground.
- Sea water has great ability in absorbing wireless radio wave, so performance will be poor when testing near the sea.
- The signal will be affected when the antenna is near metal object or put in a metal case.
- Power register was set incorrectly, air data rate is set as too high (the higher the air data rate, the shorter the distance).
- The power supply low voltage under room temperature is lower than 2.5V, the lower the voltage, the lower the transmitting power.
- Due to antenna quality or poor matching between antenna and module.

6.2 Module is easy to damage

- Please check the power supply source, ensure it is in right range. Voltage higher than max value will damage the module.
- Please check the stability of power source, the voltage cannot fluctuate too much.
- Please make sure antistatic measure are taken when installing and using, high frequency devices have electrostatic susceptibility.
- Please ensure the humidity is within limited range, some parts are sensitive to humidity.
- Please avoid using modules under too high or too low temperature.

6.3 BER(Bit Error Rate) is high

- There are co-channel signal interference nearby, please be away from interference sources or modify frequency and channel to avoid interference;
- Poor power supply may cause messy code. Make sure that the power supply is reliable.
- The extension line and feeder quality are poor or too long, so the bit error rate is high;

7 Production guidance

7.1 Reflow soldering temperature

Profile Feature	Sn-Pb Assembly	Pb-Free Assembly
Solder Paste	Sn63/Pb37	Sn96.5/Ag3/Cu0.5
Preheat Temperature min (T _{min})	100°C	150°C
Preheat temperature max (T _{max})	150°C	200°C
Preheat Time (T _{min} to T _{max})(ts)	60-120 sec	60-120 sec
Average ramp-up rate(T _{max} to T _p)	3°C/second max	3°C/second max
Liquidous Temperature (TL)	183°C	217°C
Time (tL) Maintained Above (TL)	60-90 sec	30-90 sec
Peak temperature (T _p)	220-235°C	230-250°C
Average ramp-down rate (T _p to T _{max})	6°C/second max	6°C/second max
Time 25°C to peak temperature	6 minutes max	8 minutes max

7.2 Reflow soldering curve

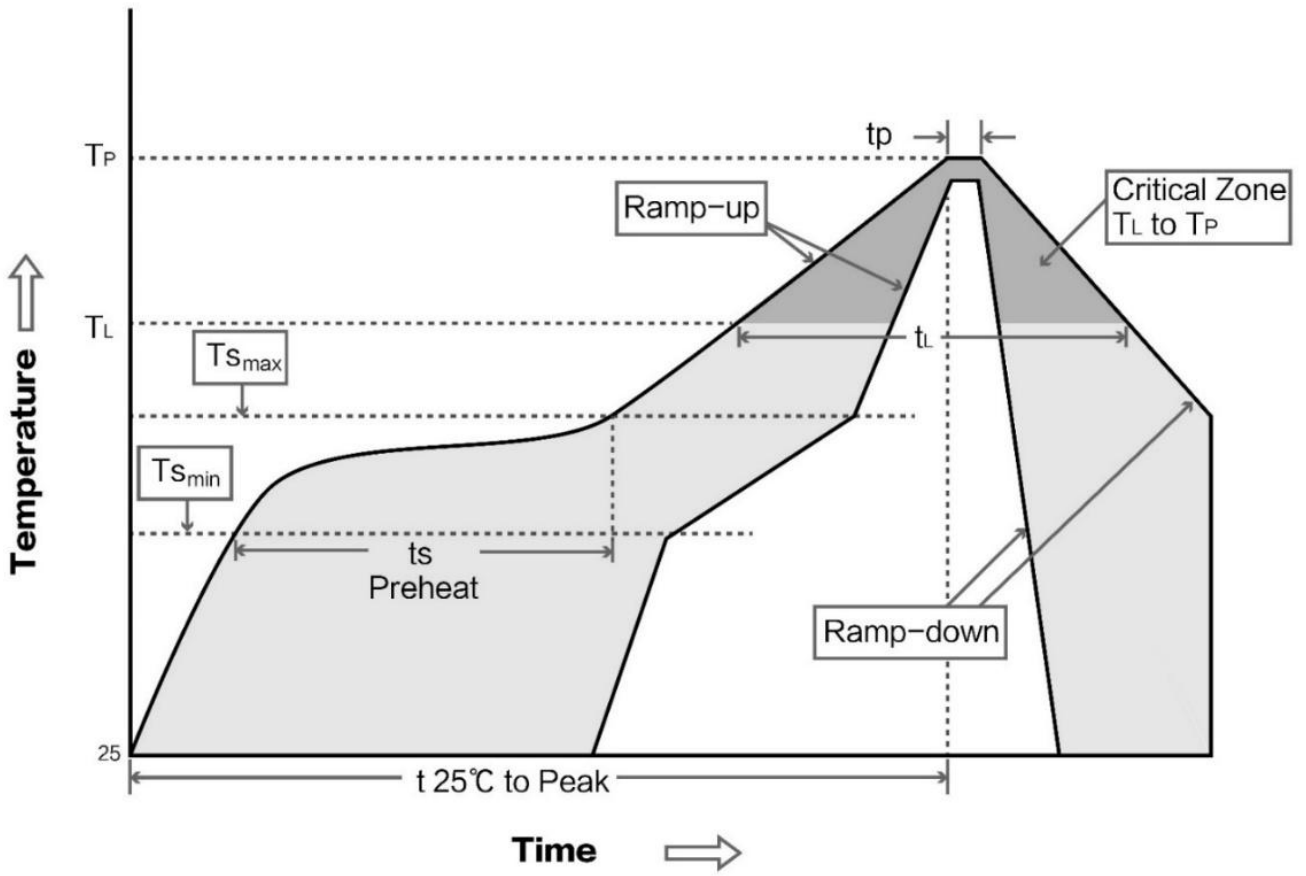

8 Package for batch order

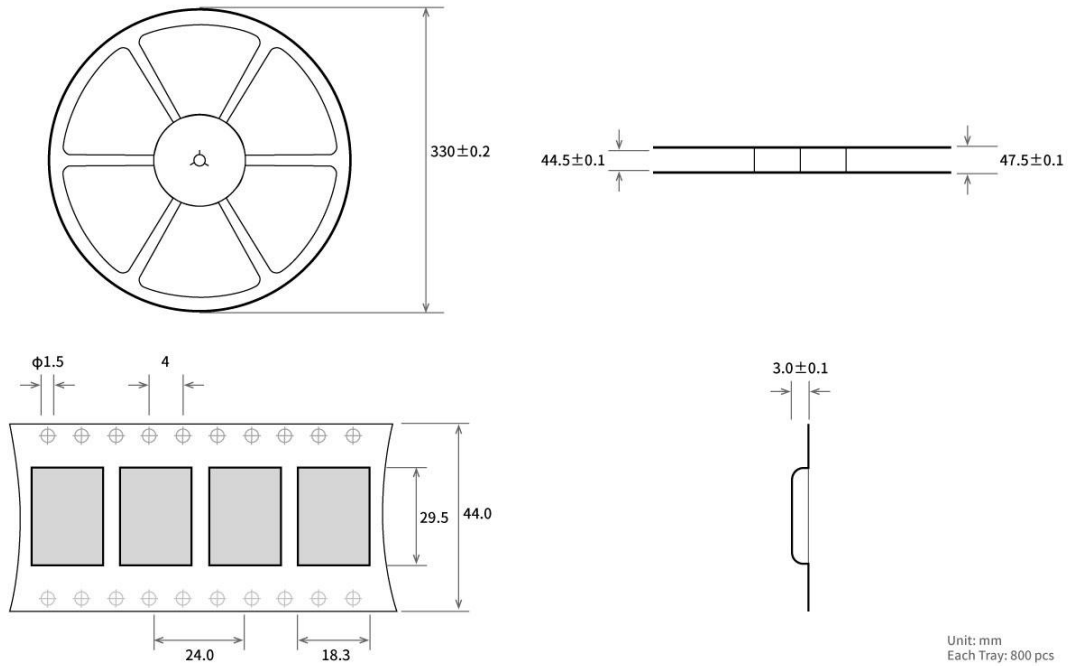

Revision history

Version	Date	Description	Issued by
1.0	2023-10-23	Initial version	Bin

About Us

Technical support: support@cdebyte.com

Documents and RF Setting download link: <https://www.cdebyte.com>

Thank you for using Ebyte products! Please contact us with any questions or suggestions: info@cdebyte.com

Web: <https://www.cdebyte.com>

Address: B5 Mould Park, 199# Xiqu Ave, High-tech District, Sichuan, China



Chengdu Ebyte Electronic Technology Co.,Ltd.